

RSS-233T - 13K Trailer

Self-Steering Air-Ride Suspension

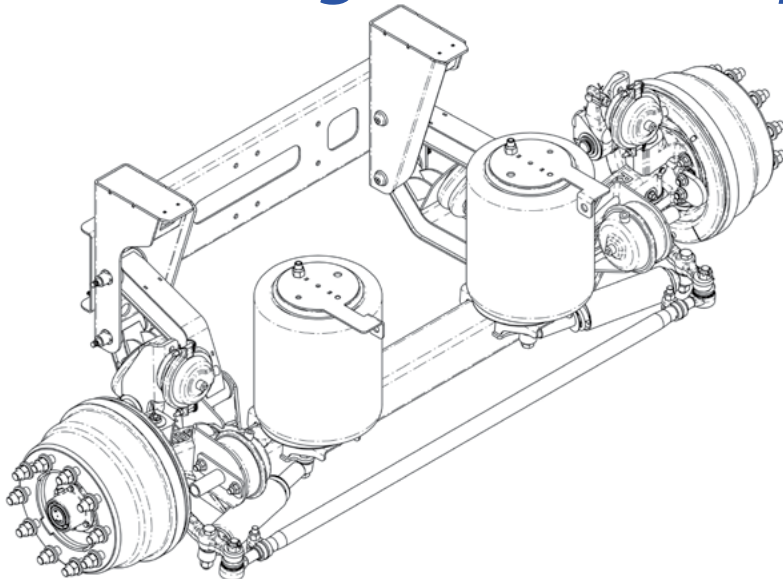

Installation and Service Manual

Suspension Identification	2
Prior to Installation	3
Suspension Mounting	4
Wheel Toe Setting	5
Air Control Kit Components - Lift Axle	6
Plumbing Example - Quick Exhaust (QE) Valves w/ Lift-In-Reverse	
Lift Axle Control Module (LACM) with Lift-In-Reverse	7
Maintenance	
Recommended Service Intervals	8
Drum Brake FAXL Components - Single-fastener-mounted air spring	
Dual-fastener-mounted air spring	9
Disc Brake FAXL Components - Single-fastener-mounted air spring	
Dual-fastener-mounted air spring	10
FAXL Components w/ Air Spring Bridge - Single-fastener-mounted air spring	
Dual-fastener-mounted air spring	11
Bushing Replacement/Torque Specifications	12
Drum Brake Fabricated Axle Components (Standard Kingpin shown)	13
Disc Brake Fabricated Axle Components (Kaiser Kingpin shown)	14
Warranty	16





PART NO:

SUSP. NO:

SERIAL NO:

GROSS AXLE WEIGHT RATING CERTIFICATION IS PER THE FINAL STAGE MANUFACTURER OR ALTERER.

THIS PRODUCT MAY BE COVERED UNDER ONE OR MORE PATENTS, ADDITIONAL PATENTS MAY BE PENDING.

www.ridewellcorp.com

(800) 641-4122

Suspension Identification Tag

The tag's **Part Number** is listed as a 606-Installation/Assembly Number when components are factory installed onto the suspension. The **Suspension Number** and **Serial Number** refer to the individual suspension model and the date of manufacture.

Refer to the suspension number/part number and serial number when contacting Ridewell for customer service, replacement parts and warranty information.

Self-Steering Suspension Option

Steerable suspensions are designed to self-steer in the forward direction only. The suspension must be raised off the ground or locked into non-steering configuration during reverse travel to avoid damaging the suspension.

Use caution when maneuvering in reverse with the steering lock engaged. The driver should maintain slow maneuvering speeds and avoid extreme turns.

1. The use of automated systems that raise/lock the lift-axle during reverse travel is strongly recommended.
2. For manual operations, Ridewell recommends installing a visual/audible indicator to assist the driver.

CAUTION Failure to lift the suspension and-or engage the steering-lock during reverse travel can cause component damage and void the warranty.

Notes and Cautions

Read through entire Installation and Service Manual (ISM) before any procedures. All work should be completed by a properly trained technician using the proper/special tools and safe work procedures.

The ISM uses two service notes to provide important safety guidelines for suspension system operation:

“NOTE”: Provides instructions or procedures to complete tasks and ensure suspension functions properly.

CAUTION Indicates a hazardous situation or unsafe practice that, if not avoided, could result in equipment damage and serious injury



Click/Scan the QR-Code to launch support webpage.
Additional kingpin and pivot bushing installation/maintenance information can be found in the "233_232-Kingpin/Bushing-Parts Guide".

Prior to Installation

Refer to the engineering drawing for narrow- or wide-track suspension dimensional requirements; available ride heights; and, the suspension operating parameters. NOTE: Narrow- or standard-track refers to a 233-13K Trailer Suspension used in conjunction with standard/narrow track-width (71.5") primary trailer axles. Wide-Track 233-13K suspensions are installed with wide-track (77.5") primary trailer axles.

Installations can vary. Procedures should be adapted for different vehicles, as needed.

- The Gross Axle Weight Rating (GAWR) is determined by the system component with the lowest load rating. Please consult with the tire, wheel, axle and brake manufacturers before installation to determine the GAWR.
- If vehicle chassis modifications are required, consult with the vehicle manufacturer to ensure that such changes are permitted.
- Welding or altering of suspension components is not permitted without the express written permission of Ridewell Suspensions.

Installer Responsibilities

The installer of the suspension has the sole responsibility for proper attachment of the suspension system to the vehicle chassis.

- The installer is responsible for locating the suspension system on the vehicle to provide the proper load distribution.
- The installer must verify that vehicle crossmembers are positioned to support the suspension at the installing location.
- The installer must verify there is sufficient clearance for proper functioning of the installed auxiliary suspension – air springs; brake chambers; steering components; axle (including axle to driveline clearance); and, tires and wheels.
- It is the installer's responsibility to determine that axle spacing conforms to any applicable federal and local bridge laws.
- The installer must verify that air reservoir volume requirements are met after installation. Consult the vehicle manufacturer or the Federal Motor Vehicle Safety Standards (FMVSS) 121 for more information.

Suspension Mounting

Refer to the suspension model engineering drawing for the suspension travel table; torque specifications; and, the spacing and clearance requirements for mounting the suspension.

The RSS-233T 13K Trailer Suspension is shipped fully assembled. If the system is taken apart for installation, the components must be reassembled with the proper torque applied (Page 15).

Weld-On Installation Procedure

Recommended locations of customer-furnished filler plates and supporting crossmembers for the hangers and air spring mounting plates are shown on the engineering drawing.

CAUTION The welding method used must develop a minimum weld tensile strength of 70,000 psi per AWS specifications.

1. Mark the desired location for the frame hangers and air spring mounting plates and customer-furnished filler plates on the frame.
NOTE: For proper support, a crossmember must be located within six inches of the leading or trailing edge of the frame hanger.
2. Check the location for sufficient clearances in both the raised and lowered positions.
3. Weld customer-furnished filler plates, as needed, to crossmembers with ¼" fillet welds down the length of the crossmember.
4. Weld customer-furnished filler plates for air spring mounting plates to frame and crossmember(s). Weld filler plates with ¼" fillet welds down the length of crossmember.
5. Weld the hangers to the frame/filler plates with 1/4" fillet welds completely around the hangers. Stop the welds 1/2" from the corners and edges.
6. Weld the air spring mounting plates to the frame/filler plates with 3/16" fillet welds all the way around the mounting plates/bridge assembly.
7. If components have been removed for installation, reinstall as shown on engineering drawing. Torque to specifications (Page 11).
8. Install/connect the air control kit (ACK) to the suspension. Check the air system installation for leaks and proper operation of controls (Page 6).
9. Perform final assembly and inspection and check the wheel toe setting (Page 5).

Bolt-On Installation Procedure

Grade-8 bolts, flanged locknuts or locknuts with hardened washers are supplied by the installer.

Refer to the engineering drawing for the range of available ride heights; spacing and clearance requirements; and, bolting pattern detail of the suspension.

Verify that wires, hoses or other components located within the frame rail are not affected by drilling.

CAUTION If recommended bolt-hole locations are not available, locate and drill bolt-holes as far apart as possible to provide the most support for the assembled suspension.

Failure to torque components to specifications can result in suspension failure and void the warranty.

Final Assembly and Inspection

1. Verify welds on hangers and air spring mounting plates. Verify all suspension component bolts/nuts are torqued to specifications (Page 15).
2. Install wheels and tires.
CAUTION When lowering an auxiliary axle on an unloaded vehicle, pressure to the load air springs must be reduced to below 10 psi.
Failure to reduce air pressure could cause the vehicle's axles to rise from the ground and the vehicle could roll in an unsafe manner.
3. Check that tires are inflated to recommended pressure. Check wheel hubs for proper level of lubricant recommended by the manufacturer.
4. Lift the axle to the raised position. Check the air system tubing and connections for leaks.
5. Check that wheels can rotate freely and that brakes and slack adjusters are properly adjusted.
6. Raise and lower suspension assembly (wheels and tires installed) through entire range of travel. Make sure there are sufficient clearances for air springs, brake chambers and other components.
7. Check the vehicle's reverse travel options:
 - 7.1. Check steer lock operation.
 - 7.2. Check automated system (if installed) to make sure that suspension raises/locks wheels during reverse travel.
CAUTION Failure to check reverse travel operations can result in component damage and void the suspension warranty.
8. Check wheel toe-in setting (between 1/32" and 3/32"). Adjust if necessary (page 5).

Wheel Toe Setting

Wheel toe is the relationship of the distance between the front of the tires and the distance between the rear of the tires on the same axle.

When the front distance is less than the rear distance, the wheels are in a “toe-in” (positive toe) condition.

The correct setting for the RSS-233 13K Trailer Suspension toe-in is a toe-in between 1/32” and 3/32”.

Check Wheel Toe Setting

1. Deflate the air springs.
2. Lift the axle enough for tires to rotate freely. Make sure axle is level. Support with jack stands.
3. Position tires to point straight ahead. Spin each tire. Use a piece of chalk to mark a line on the center tread all the way around the tire.
4. Use the centerline mark to measure the distance from the front of the tire to the frame. Measure the distance from the back of the tire to the frame.
5. Subtract the front of the tire distance from the rear distance to obtain the wheel toe setting.

Adjust Wheel Toe

1. Loosen clamps on both ends of the tie rod. Twist the tie rod forward/backward to move the front of the tire towards or away from the frame.
2. Continue rotating the tie rod until the proper toe-in setting is achieved.
3. Torque tie-rod clamps to 60-80 ft-lb (81-108 N-m).

Regulate load with air spring pressure

The load capacity of the auxiliary axle is adjusted by increasing or decreasing the pressure to the air springs. By applying more air, the lift axle takes on a greater percentage of the load’s weight. The load capacity is decreased as the air pressure decreases.

Accurate readings of the load capacity can be obtained by parking a loaded vehicle over a calibrated scale and lowering the axle onto the scale. The air pressure to the air springs is manually adjusted up or down to obtain the axle load weight at various air pressures.

⚠ CAUTION Do not exceed the rated load capacity of the suspension system or other components. Exceeding the capacity can cause component failure and void the warranty.

Air Control Kit Components - Lift Axle

The air control kit (ACK) consists of a pressure regulator with a gauge connected to an air valve controlled by a manual knob or an electric switch. The operator uses the ACK to control the pressure to the air springs to support different loads.

CAUTION The installer is responsible for making sure that air system requirements comply with the appropriate Federal Motor Vehicle Safety Standards.

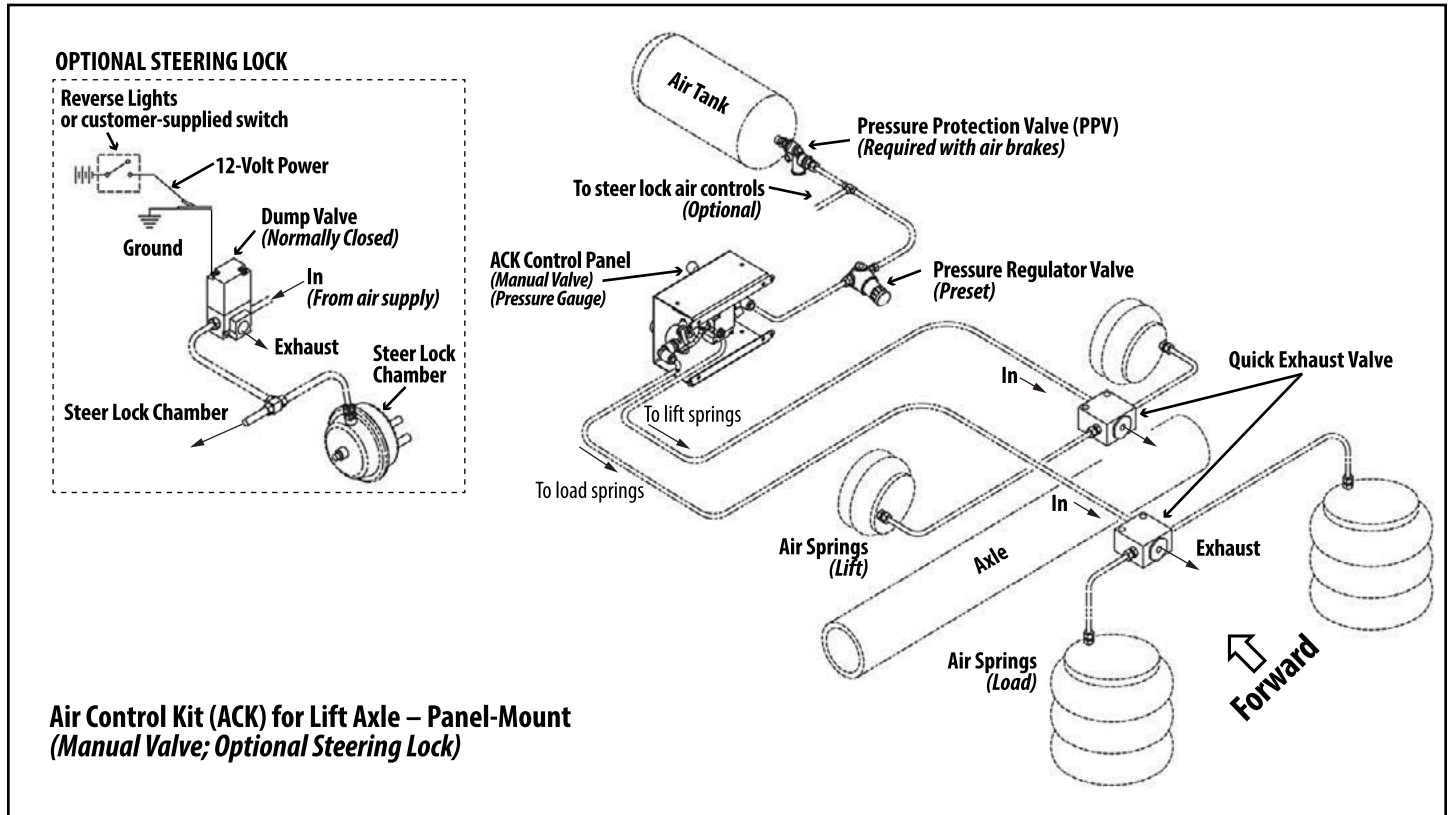

TROUBLESHOOTING – AIR CONTROL KIT

Problem	Possible Cause	Solution
Air springs fill but do not exhaust.	<ul style="list-style-type: none"> – Obstructed air line. – Faulty controls wiring. – Manual override pushed in. 	<ul style="list-style-type: none"> – Check for pinched/blocked lines. – Check wiring w/ voltmeter. Correct wiring/installation. – Release manual override.
Air system leaks down after a short period of time.	<ul style="list-style-type: none"> – Leak in air system beyond accepted standards. NOTE: Some valves will leak at an acceptable rate. 	<ul style="list-style-type: none"> – Pressurize system and spray soapy water solution onto tubing, valves and fittings. Check for bubbles (leaks). – Check that tubing cuts are straight and smooth. Re-cut and reassemble fitting joints, if necessary.
Auxiliary unit will not stay up	<ul style="list-style-type: none"> – Loose air fitting connection/Damaged air lines. – Air lines to lift and load air springs are reversed. – Damaged or worn air springs. 	<ul style="list-style-type: none"> – Check and retighten fittings. Repair or replace component, as necessary. – Check installation. Air line from regulator goes to (load) air springs. – Replace air spring if worn or damaged.
Auxiliary unit not achieving correct lift	<ul style="list-style-type: none"> – Air lines to lift and load air springs are reversed. – Lift air springs do not have proper air pressure. – Interference with driveline/other chassis components. – Air control system not installed correctly. 	<ul style="list-style-type: none"> – Check installation. Air line from regulator goes to (load) air springs. – Check for loose fittings or worn/damaged lines. Verify air tank pressure with gauge. – Visually inspect auxiliary unit operation for proper clearance. Retighten any loose fasteners. – Check air control kit installation; refer to OEM installation procedures.

**Panel-Mount ACK for Lift Axle w/ Lift-In-Reverse
(Electric Valve; Optional Steering Lock)**

Lift-In-Reverse-Wiring Diagram

Note: Relay is required only for lift-in-reverse operation

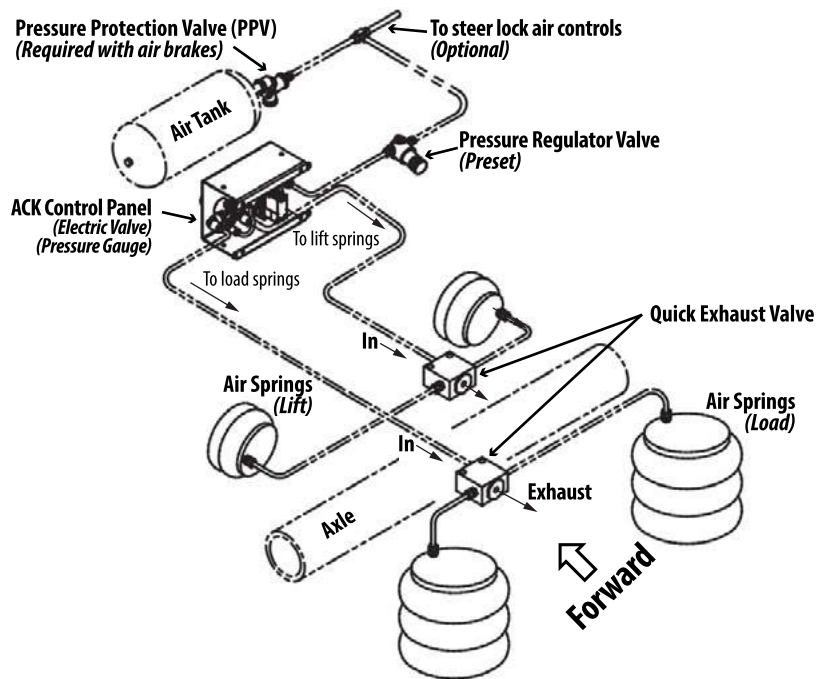
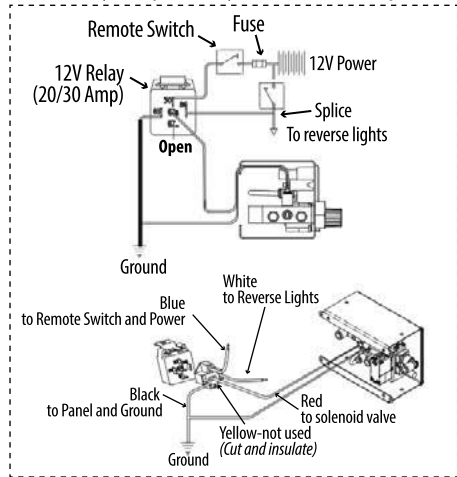

Figure 1.
Plumbing Example - Quick Exhaust (QE) Valves w/ Lift-In-Reverse

ACK-Lift Axle Control Module with Lift-In-Reverse

Lift-In-Reverse-Wiring Diagram

Note: Relay is required only for lift-in-reverse operation

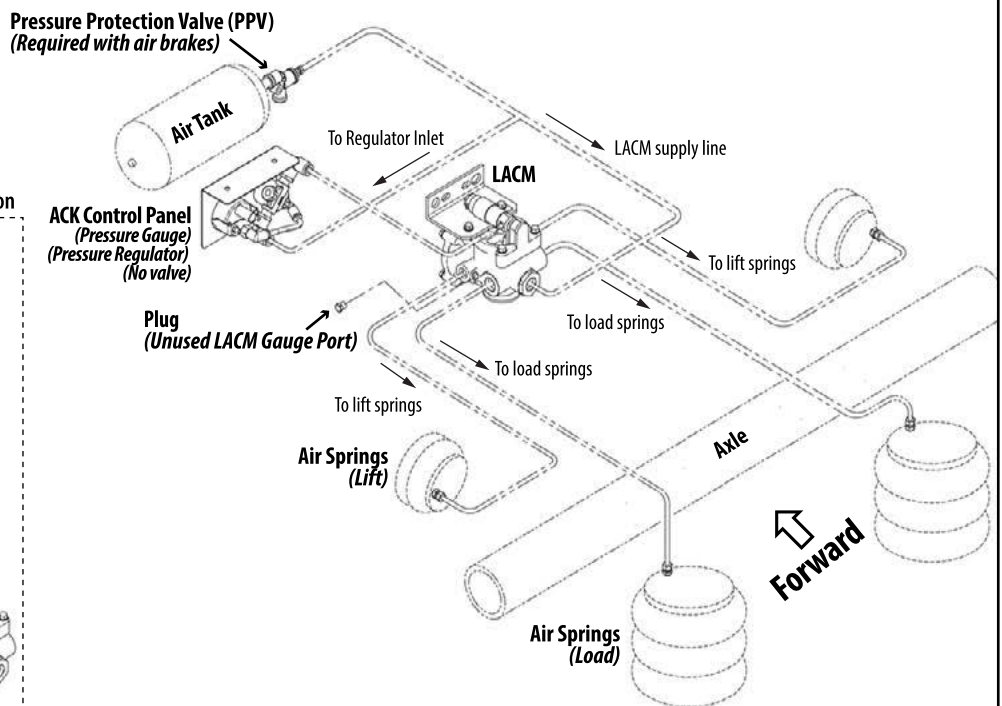
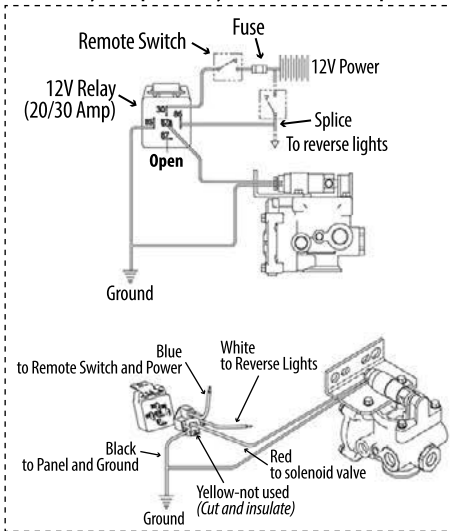

Figure 2.
Plumbing Example - Lift Axle Control Module (LACM) with Lift-In-Reverse

Recommended Service Intervals

Ridewell Suspensions recommends these minimum service intervals for standard duty, on-highway usage suspension applications.

More frequent service intervals are recommended for off-highway/heavier duty applications.

Daily/Pre-Trip Inspections

- ___ Visually inspect suspension structure for signs of damage or excessive wear.
- ___ Check for loose or missing bolts/nuts. Check for irregular movement in suspension system components.
- ___ Check tires for proper inflation, road damage or excessive wear.
- ___ Check wheel-ends for obvious signs of lubricant leakage. Check for missing components.
- ___ Make sure air controls are operating properly. Drain all moisture from air reservoirs.

First 6,000 miles of use

- ___ Torque all bolts/nuts to specifications (Page 10).

Every 12,000 miles of use

- ___ Lubricate Brake Cam and Slack Adjuster.
- ___ Grease kingpin thrust bearings. Apply grease in upper and lower grease fittings until new grease is visible at the purge location. Wipe the excess grease from purge areas and grease fittings.
- ___ Inspect steering damper for damage/wear.
- ___ Inspect air springs for damage/excessive wear. Torque bolts/nuts to specifications (Page 10).
- ___ Check air system for leaks.

First 50,000 miles of use

- ___ Check wheel-end/knuckle for excessive play.
- ___ Inspect tie-rod and tie-rod ends for excessive damage/wear. Lubricate tie-rod ends. Verify tie-rod boot is in place and completely over the end of tie-rod. Replace entire tie-rod end if boot is damaged.
- ___ Check pivot bushings for wear.
- ___ Torque all suspension system component bolts/nuts to specifications (Page 10).
- ___ Check (reverse) steer lock operation (if equipped).
- ___ Verify operation of manual/automatic lift-in-reverse control system (if equipped).

Annual/100,000 Miles Inspection

- ___ Inspect pivot connections for worn bushings/wear washers. Replace if necessary. Torque pivot hardware to specifications (Page 10).
- ___ Check lubrication level in wheel-ends. Refill/Replace lubricant as needed. *(TMC RP 631-Wheel End Lubrication Procedure)*
- ___ Check frame hanger and air spring mounting plate connections to frame.
- ___ Check air system for leaks.
- ___ Test air tank pressure protection valve (PPV) if equipped.
- ___ Check brakes/brake chambers for damage/function.

⚠CAUTION Failure to exhaust all pressure from the air system before vehicle work can cause serious injury.

⚠CAUTION Failure to torque suspension components to specifications can result in suspension failure and void the warranty.

Refer to these Technology & Maintenance Council (TMC) Recommended Procedures for additional information:

RP 609	Self-Adjusting/Manual Brake Adjuster Removal, Installation and Maintenance
RP 618	Wheel Bearing Adjustment Procedure
RP 619	Air System Inspection Procedure
RP 622	Wheel Seal and Bearing Maintenance
RP 631	Wheel End Lubrication Procedures
RP 643	Air Ride Suspension Maintenance Guidelines
RP 645	Tie-Rod End Inspection/Maintenance
RP 651	Steer Axle Maintenance Guidelines

Available Wheel-End Lubricants

Lubricant Type	Part No.	Item Description
Mineral Oil	380008G	(CITGO) MP GearOil 631310001-80W-90
Synthetic Oil	1980006	(SHELL) Synthetic API GI-5 75W-90 Oil
Synthetic Hard-Pack Grease	1980007	(CITGO) Synthetic Grease

Bushing replacement kit includes traditional hardware to replace factory installed Huck® Fasteners.

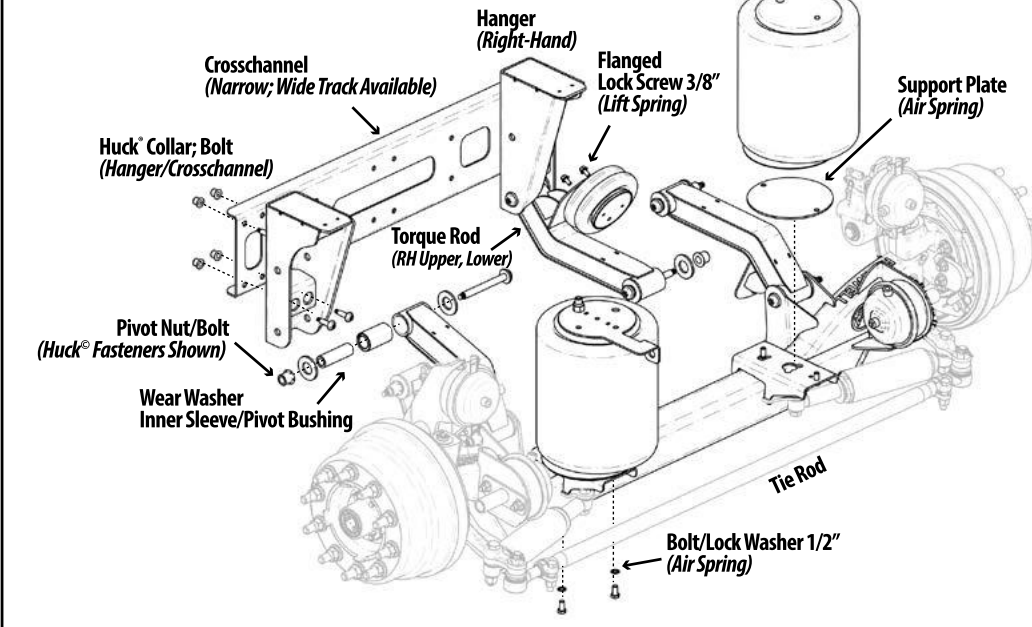

Figure 3.
13K Trailer Suspension-
Drum Brake FAXL Components –
Single-fastener-mounted air spring

Bushing replacement kit includes traditional hardware to replace factory installed Huck® Fasteners.

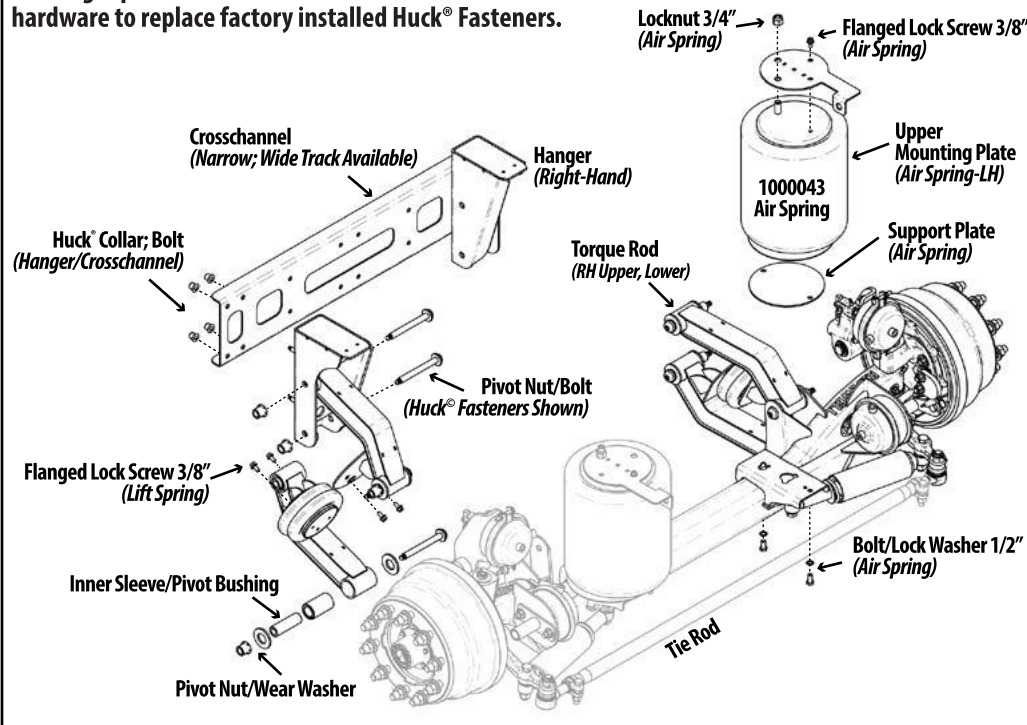

Figure 4.
13K Trailer Suspension-
Drum Brake FAXL Components –
Dual-fastener-mounted air spring
Requires dual-fastener air spring
(P/N 1000043)

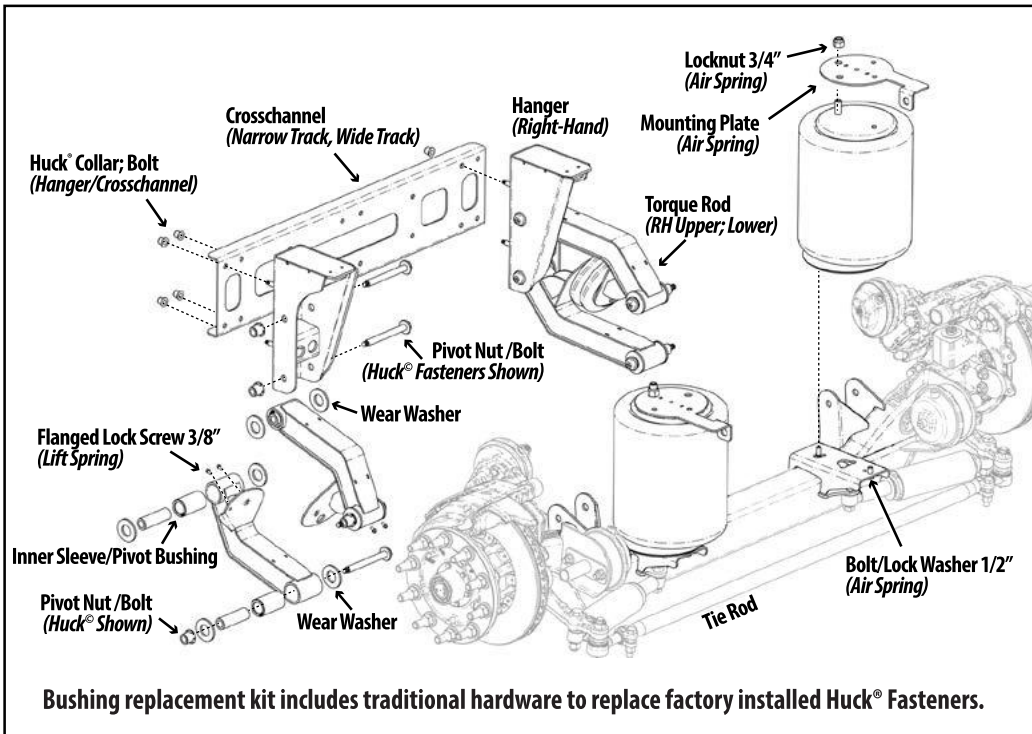

Figure 5.
13K Trailer Suspension-
Disc Brake FAXL Components –
Single-fastener-mounted air spring

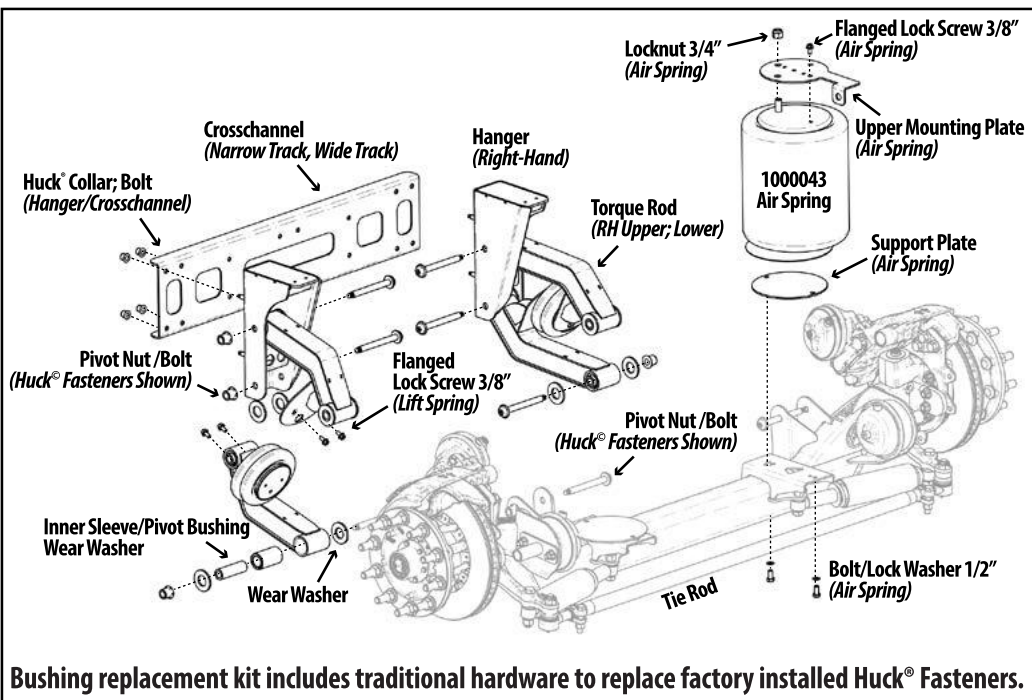

Figure 6.
13K Trailer Suspension-
Disc Brake FAXL Components –
Dual-fastener-mounted air spring
Requires dual-fastener air spring
(P/N 1000043)

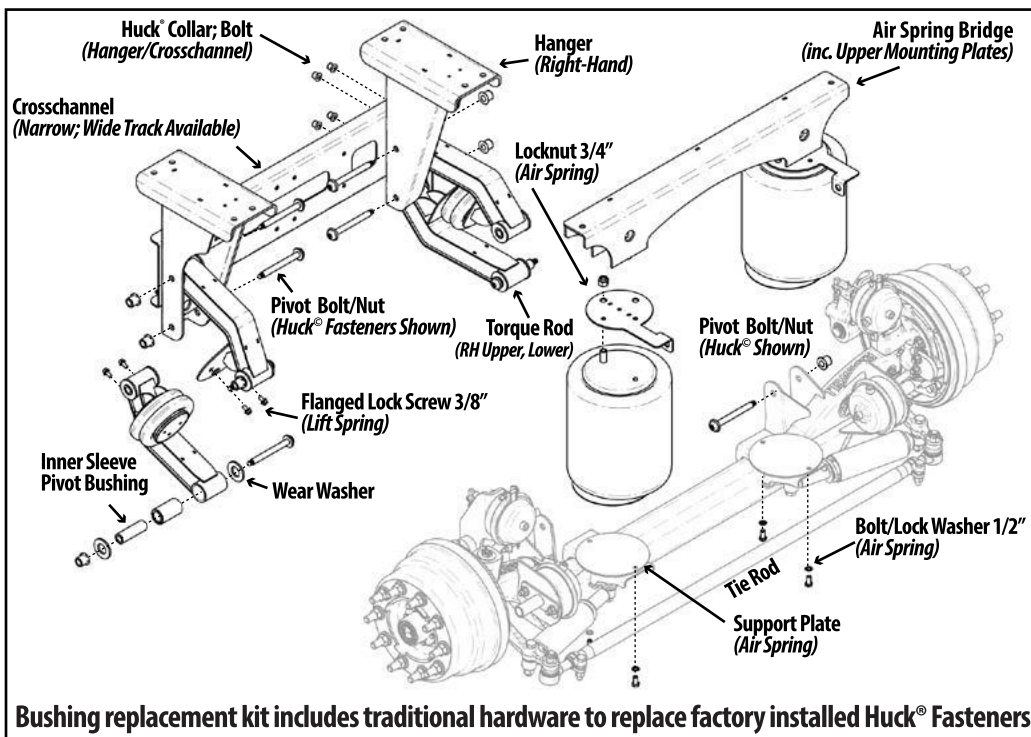

Figure 7.
13K Trailer Suspension Drum Brake FAXL Components including Air Spring Bridge – Single-fastener-mounted air spring

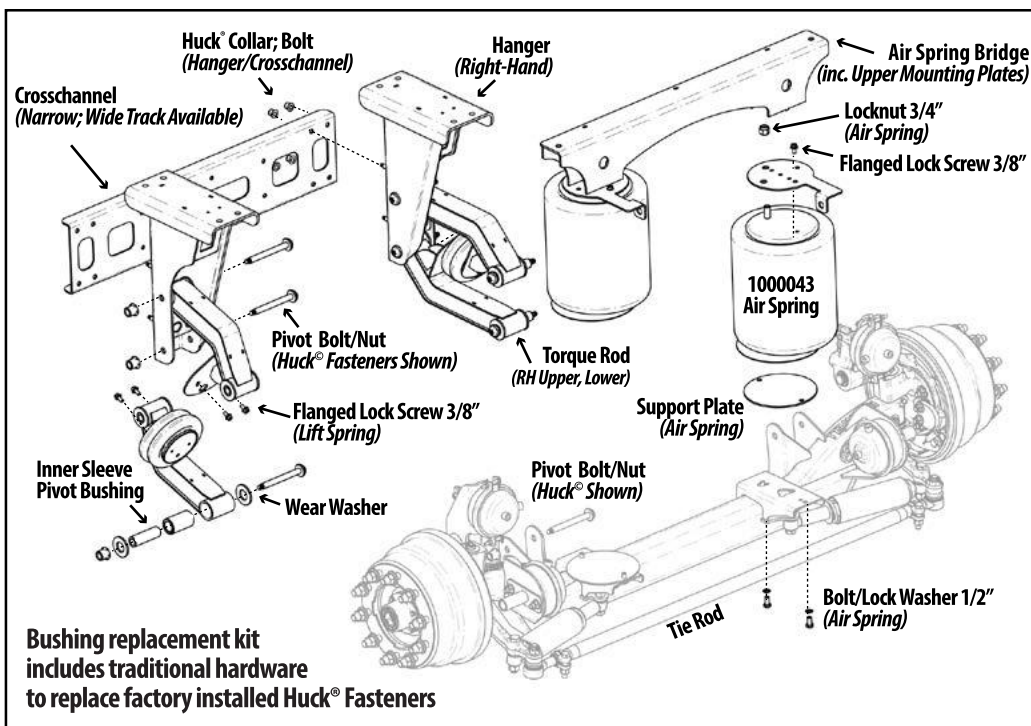

Figure 8.
13K Trailer Suspension Drum Brake FAXL Components including Air Spring Bridge – Dual-fastener-mounted air spring
Requires dual-fastener air spring (P/N 1000043)

233T 13K TRAILER SUSPENSION – BUSHING REPLACEMENT/TORQUE SPECIFICATIONS

Part Number	Item Description	Size	Torque Values	
			foot-pound	Newton-meter
6040188 (Kit)	Traditional Hardware (HHCS/Locknut)	3/4"-16NF	310 ft-lb	420 N-m
6040187 (Kit)	No Pivot Hardware	NA		
Fasteners	Locknut (Single-Fastener-Mounted Air Spring)	3/4"-16NF	50 ft-lb	68 N-m
	Flanged Lock Screw (Dual-Fastener-Mounted A/SPG)	3/8"-16NC	25 ft-lb	35 N-m
	Hex Head Cap Screw-HHCS (Air Spring; Lower)	1/2"-13NC	50 ft-lb	68 N-m
	Flanged Lock Screw (Lift Spring)	3/8"-16NC	25 ft-lb	35 N-m
	Locknut (Tie Rod/Steering Damper)	3/4"-10NC	160 ft-lb	217 N-m

Torque values reflect a lubricated thread condition (Nuts are pre-lubed). Do not overtorque.

CAUTION Suspension is shipped with minimal torque applied to fasteners. All fasteners must be re-torqued after first 6,000 miles of operation. Failure to install and maintain fasteners at torque specifications could result in suspension failure and void the warranty.

Vehicle Preparation

Park the vehicle on a level surface. Chock wheels to keep vehicle from moving.

Exhaust all air from the air system. Disassemble suspension, if necessary, to reach pivot connections.

CAUTION Failure to properly chock wheels and exhaust the air system could allow vehicle/suspension movement resulting in serious injury.

Bushing Replacement Procedure

Replace the eight pivot connection bushings and hardware at the same time (Figure 9).

New wear washers included in all bushing kits.

NOTE: Suspensions purchased before October 2018 do not use wear washers at the pivot connection.

1. Remove Huck® Collar by cutting/grinding. Take pivot connection apart. Discard pivot hardware. Discard wear washers.
2. Remove bushing assembly and discard.
3. Clean torque rod eye of debris/corrosion with a wire brush before installing bushing assembly. NOTE: Bushing assembly before October 2018 consists of two bushing halves and inner sleeve.
4. Apply Energy Suspensions® Formula 5 Prelube to bore (inside) of the replacement bushing. NOTE: Do not substitute - urethane bushing lubricant included with all replacement kits.
5. Install (press) bushing into the torque rod eye. NOTE: Mallet/press needed to install bushing.
6. Press inner sleeve into the installed bushing. Center the sleeve inside the bushing so that the sleeve ends extend slightly past the bushing sides.

7. Assemble the pivot connection with one wear washer on each side of the bushing. The inner sleeve of the bushing must be flush with or extend slightly past the outside of the wear washers after assembly.
8. Torque pivot hardware to specifications (chart/engineering drawing).
9. Reassemble suspension, if necessary. Torque to specifications (chart/engineering drawing).
10. Check wheel toe-in setting (between 1/32" and 3/32") and adjust, if necessary (page 5).

CAUTION Failure to torque pivot hardware can result in suspension failure and void the warranty.

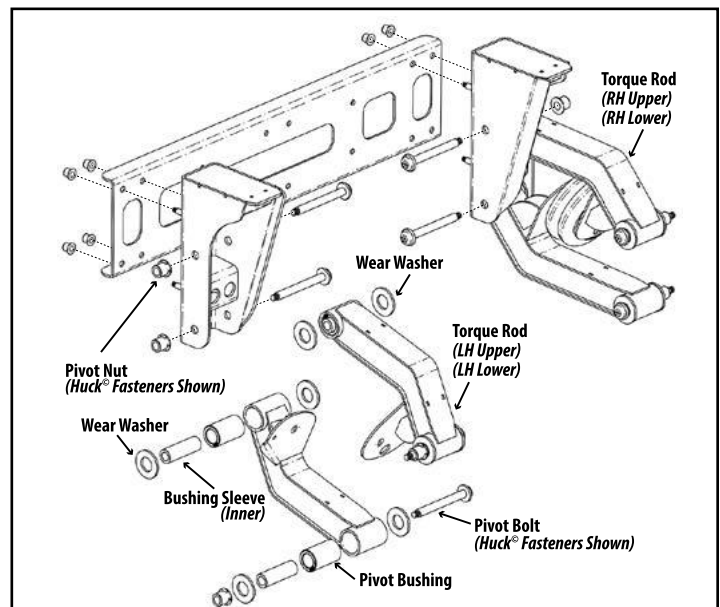

Figure 9. Bushing replacement kit includes traditional hardware to replace factory installed Huck™ fasteners.

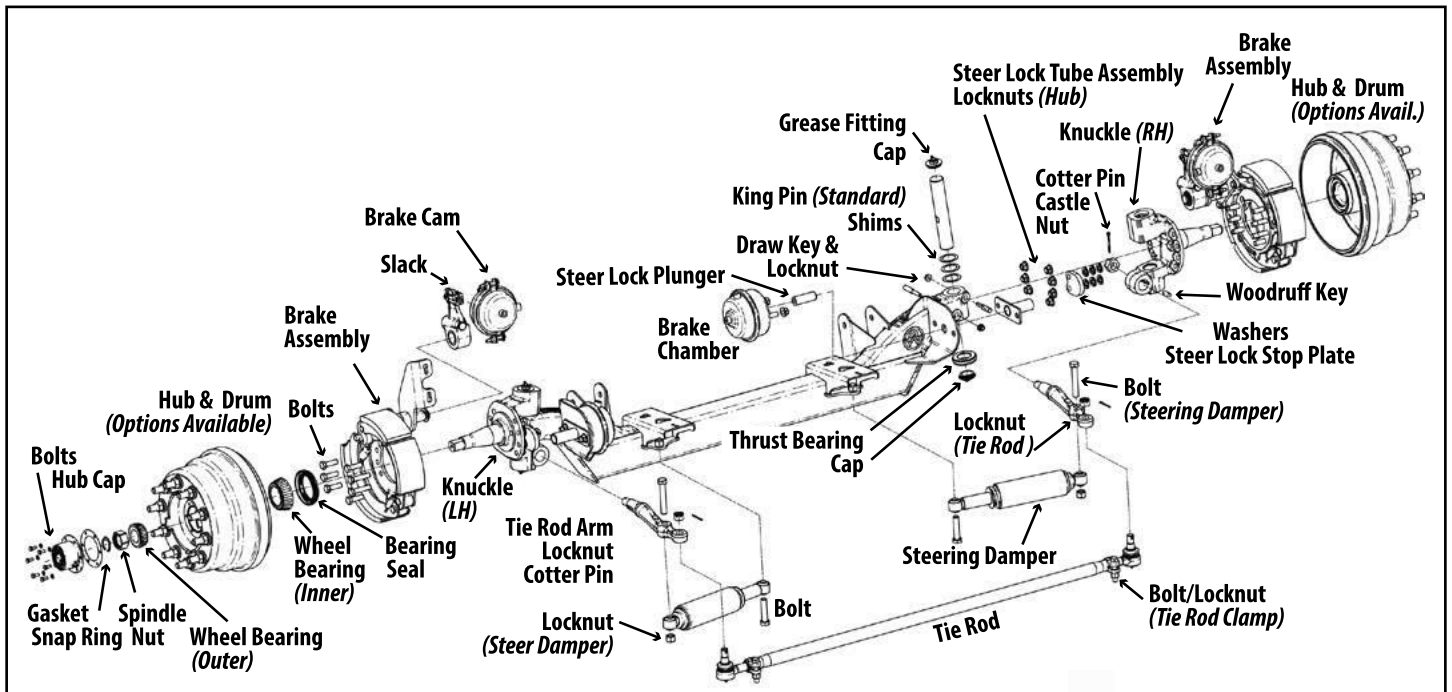

Figure 10.
Drum Brake Fabricated Axle (FAXL) Components (Steer-Lock; Standard Kingpin shown)
(Reference only. Drum brake fabricated axle can be configured with Kaiser Kingpin. Refer to the engineering drawing for individual component part numbers.)

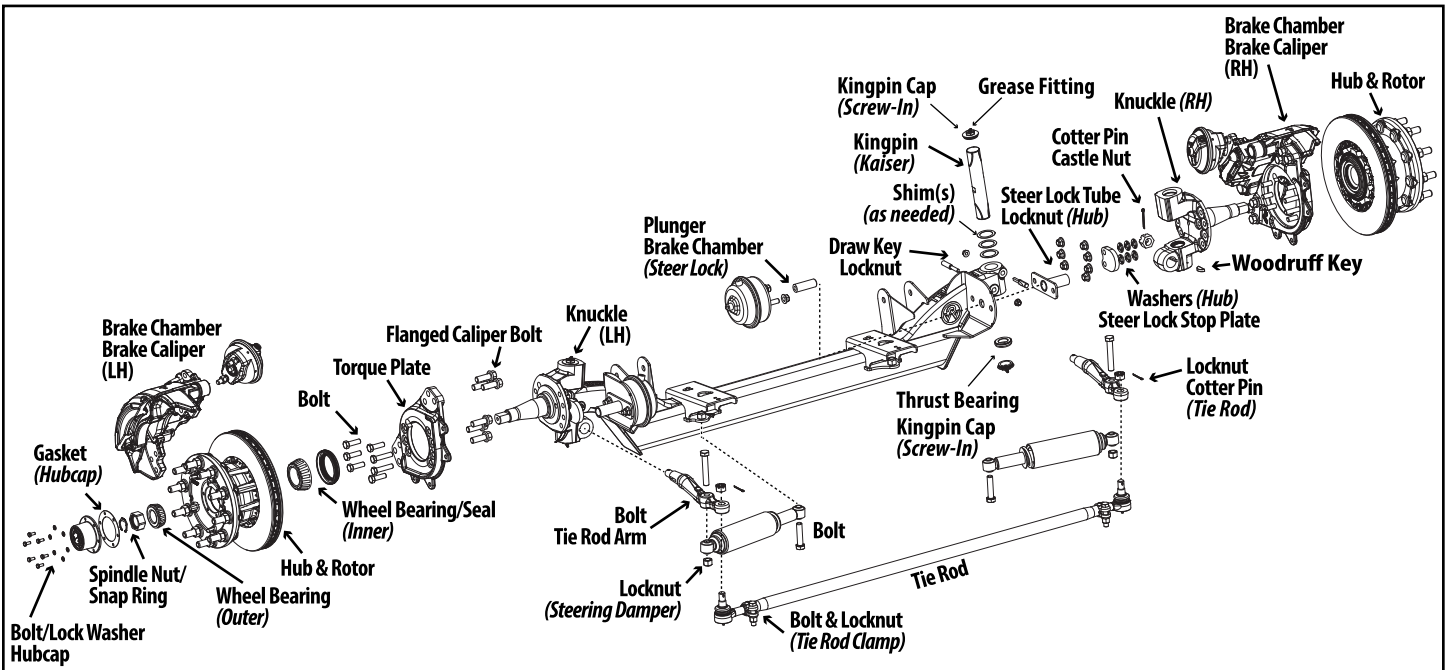

Figure 11.
Disc Brake Fabricated Axle (FAXL) Components (Steer-Lock; Kaiser Kingpin shown)
(Reference only. Disc brake fabricated axle can be configured with Standard Kingpin. Refer to the engineering drawing for individual component part numbers.)

Terms and coverage in this warranty apply only to the United States and Canada.

Ridewell Suspensions warrants the suspension systems manufactured by it to be free of defects in material and workmanship. Warranty coverage applies only to suspensions that have been properly installed, maintained and operated within the rated capacity and recommended application of the suspension. The responsibility for warranty coverage is limited to the repair/replacement of suspension parts. The liability for coverage of purchased components is limited to the original warranty coverage extended by the manufacturer of the purchased part.

All work under warranty must have prior written approval from the Ridewell warranty department. Ridewell has the sole discretion and authority to approve or deny a claim and authorize the repair or replacement of suspension parts. All parts must be held until the warranty claim is closed.

Parts that need to be returned for warranty evaluation will be issued a Returned Materials Authorization (RMA). Parts must be returned to Ridewell with the transportation charges prepaid. The transportation charges will be reimbursed if the warranty claim is approved.

This non-transferable warranty is in lieu of all other expressed or implied warranties or representations, including any implied warranties of merchantability or fitness or any obligations on the part of Ridewell. Ridewell will not be liable for any business interruptions, loss of profits, personal injury, any costs of travel delays or for any other special, indirect, incidental or consequential losses, costs or damages.

Contact the Ridewell Warranty Dept. at 417.833.4565 - Ext. 135, for complete warranty information.